



**INCLUDES 1 YEAR PARTS + LABOR / 5 YEAR COMPRESSOR WARRANTY**  
**SST-60 2 DOOR SANDWICH/SALAD PREP REFRIGERATOR**

**Dimensions**

Exterior Dimensions (WxDxH)	60" x 29.5" x 42.5"
Interior Dimensions Top (WxDxH)	56.25" x 13.5" x 8.5"
Interior Dimensions Bottom (WxDxH)	56" x 19.5" x 24"
Cutting Board Dimensions (WxDxH)	60" x 11.5" x .75"
Net Volume (cu. ft.)	15 cu. ft.
Gross Weight	306 lbs
Packaging Dimensions (WxDxH)	65" x 34.5" x 46.5"
Electrical Cord Length	98.5"

**Cooling**

Temperature Range	32° - 40° F
Refrigerant	R134a
Maximum Ambient Temperature Rating	90° F
Defrosting	Automatic
Temperature Display	Yes
Temperature Controller	Digital
H/P	1/2

**Construction**

Exterior Material	430 series stainless steel
Interior Material	304 series stainless steel
Insulation Material	Foamed in place polyurethane
Shelf Material	Plastic coated steel
Shelf Load Capacity	90 lbs
*Does not include pans	

**Electrical**

Voltage	120
Amps	8.3
Hz	60

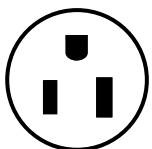
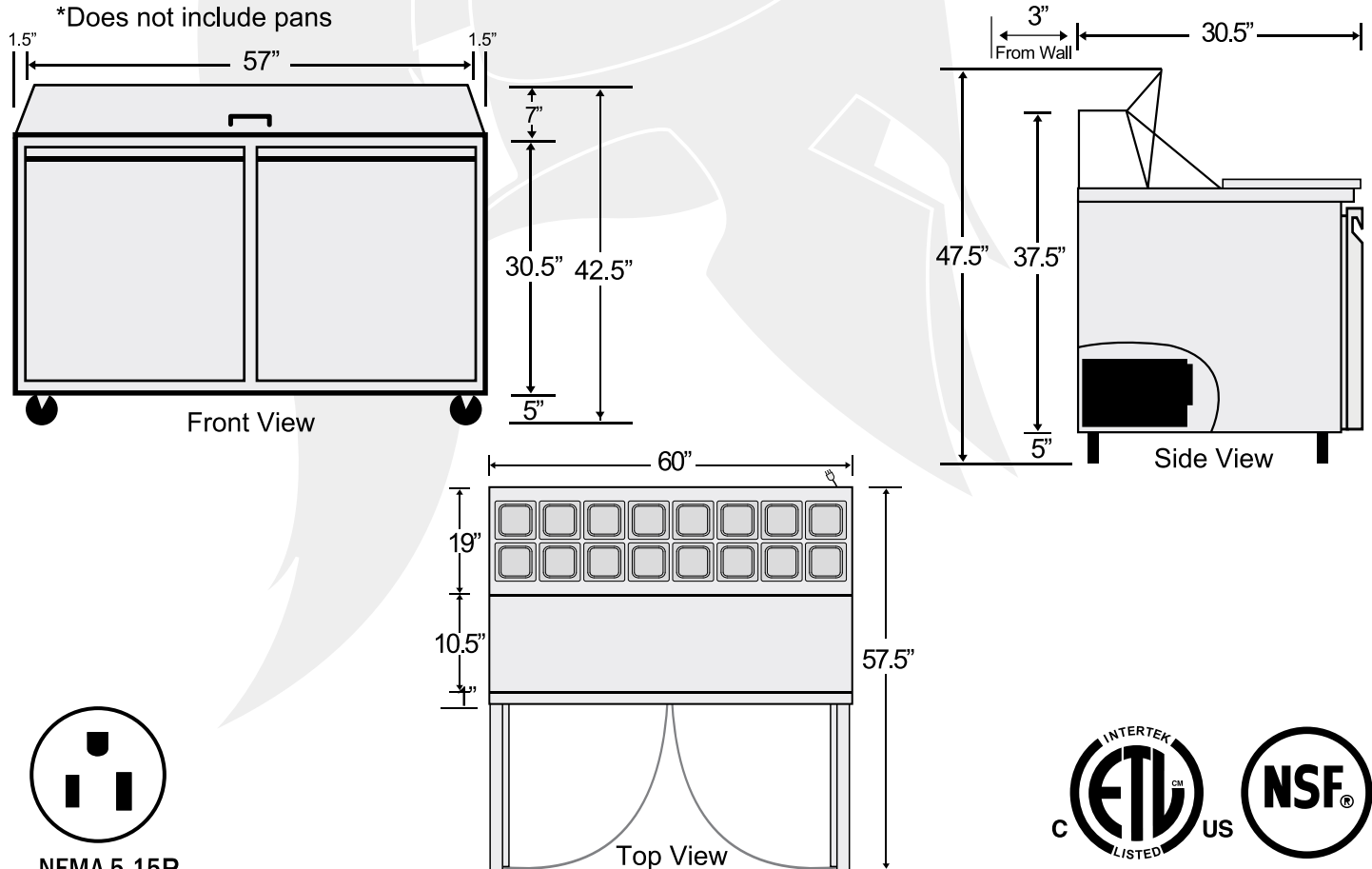

NEMA 5-15P

