



INCLUDES 1 YEAR PARTS + LABOR / 5 YEAR COMPRESSOR WARRANTY
STF-72 3 DOOR REACH-IN FREEZER

Dimensions

Exterior Dimensions (WxDxH)	81" x 32.25" x 82.5"
Interior Dimensions (WxDxH)	76.25" x 27" x 60.25"
Net Volume (cu. ft.)	72 cu. ft.
Gross Weight	745 lbs
Packaging Dimensions (WxDxH)	82" x 34" x 84.5"

Cooling

Temperature Range	-7.5° - 0° F
Refrigerant	R404a
Maximum Ambient Temperature Rating	100.4° F
Defrosting	Automatic
Temperature Display	Yes
Temperature Controller	Digital
H/P	1 ¼

Construction

Exterior Material	430 series stainless steel
Interior Material	304 series stainless steel
Insulation Material	Foamed in place polyurethane
Shelf Material	Plastic coated steel
Shelf Load Capacity	120 lbs

Electrical

Voltage	120
Amps	12.8
Hz	60
Phase	1

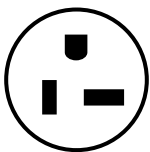
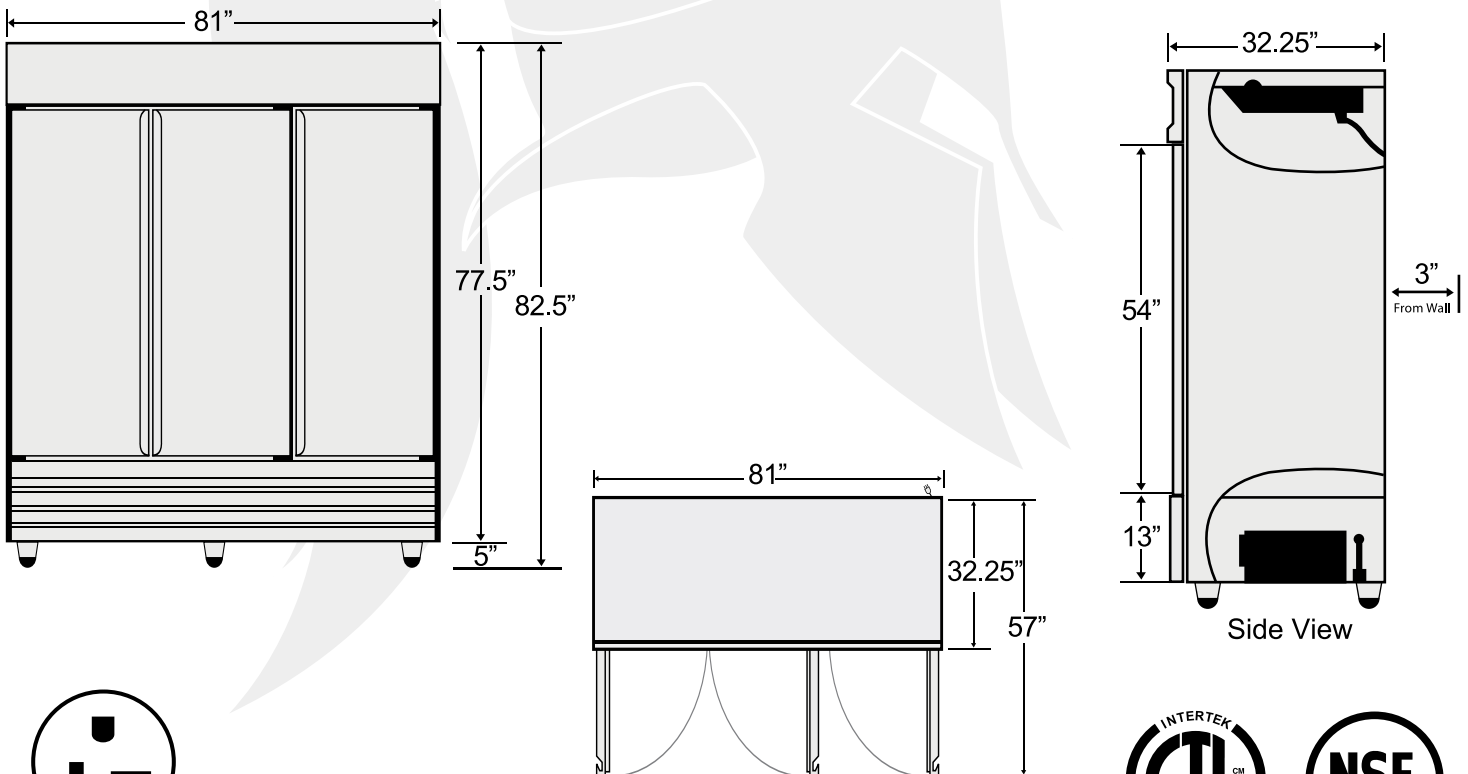

NEMA 5-20

