

## Refrigerated Chef Bases KCB Series

KCB-60-2M | KCB-74-4M  
KCB-83-4M | KCB-96-4M

### Durable Design

- Created to endure the everyday stress of the commercial kitchen environment, to protect your long term investment and guarantee superior food preservation
- Digital temperature display
- Simple plug-in installation
- Marine edge

### Energy Efficient

- Foamed-in place high-density polyurethane insulated body, CFC-Free
- Environmentally friendly R-290 refrigerant

### Superior Quality

- Designed for mobility, reliability & efficiency in commercial kitchens
- 4" swivel castors with front brakes
- Entirely self-contained system
- Forced air refrigeration
- Stainless Steel interior & exterior
- Temperature range : 33°F to 45°F



Project Name:	
Location:	
Item:	Qty:
Model:	



5659 Royalmount Ave.  
Montreal, QC, Canada H4P 2P9  
Telephone: 514.737.9701 / Toll Free: 888.275.4538  
Fax: 514.342.3854 / Toll Free: 877.453.8832  
sales@mvpgroupcorp.com / mvpgroupcorp.com

12000 Biscayne Blvd., Suite # 108  
Miami, FL, United States 33181  
Telephone: 786.600.4687 / Toll Free: 844.218.8477  
Fax: 786.661.4100

# Refrigerated Chef Bases KCB Series

KCB-60-2M | KCB-74-4M  
KCB-83-4M | KCB-96-4M

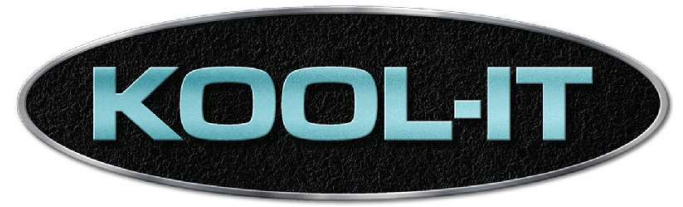

KCB-60-2M



KCB-74-4M



KCB-83-4M



KCB-96-4M

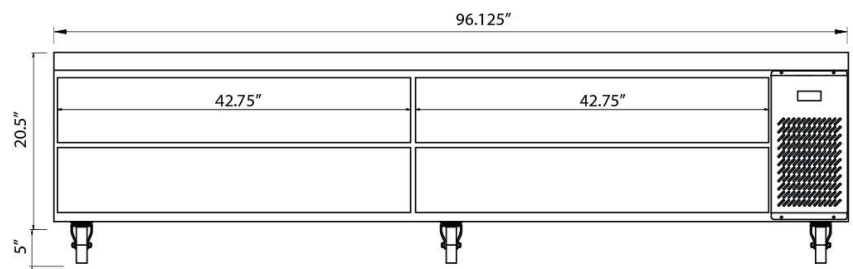
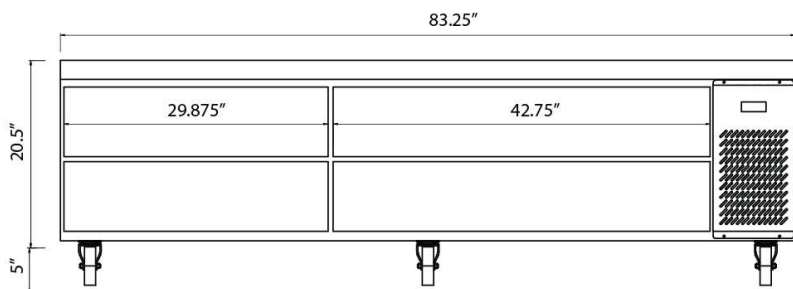
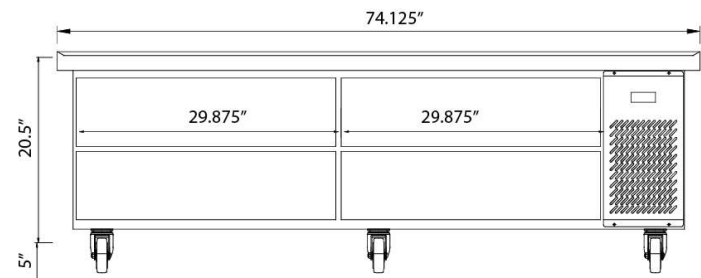
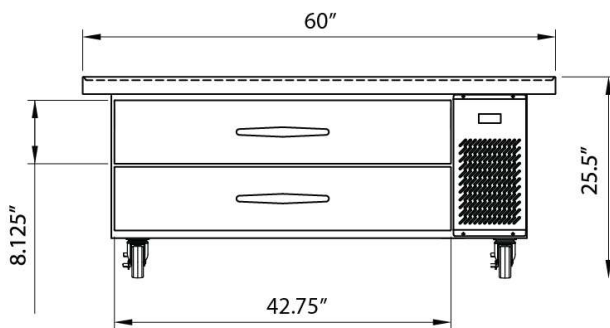

Model Number	Internal Dimensions (W x D x H inches)	External Dimensions (W x D x H inches)	Capacity (cubic feet)	Number of Drawers	Full Size 4" Pans Capacity Not Included	Horsepower	Amps	Gross Weight (lbs.)
KCB-60-2M	60 X 30.5 X 25.5	42.8 X 24.6 X 16.5	9.8	2	6	1/5	3.0	262
KCB-74-4M	74.125 X 30.5 X 25.5	57.6 X 24.6 X 16.5	14.3	4	8	1/5	3.0	309
KCB-83-4M	83.25 X 30.5 X 25.5	70.5 X 24.6 X 16.5	17.2	4	10	1/4	3.5	348
KCB-96-4M	96.125 X 30.5 X 25.5	83.3 X 24.6 X 16.5	21.4	4	12	1/4	3.5	377



These units are designed for maximum performance in an air-conditioned area of 75°F ambient temperature and 55% relative humidity. There must be adequate ventilation at the top, sides & rear of the unit for proper operation. All chef bases have a voltage of 115/60/1 and NEMA 5-15 Plug.

Warranty: 36 months parts and labor.  
Additional 24 months on compressor (part only)

KOOL-IT is a registered trademark of MVP Group.  
Specifications subject to change without notice.



5659 Royalmount Ave.  
Montreal, QC, Canada H4P 2P9  
Telephone: 514.737.9701 / Toll Free: 888.275.4538  
Fax: 514.342.3854 / Toll Free: 877.453.8832  
sales@mvpgroupcorp.com / mvpgroupcorp.com

12000 Biscayne Blvd., Suite # 108  
Miami, FL, United States 33181  
Telephone: 786.600.4687 / Toll Free: 844.218.8477  
Fax: 786.661.4100