



MODELS

KFM-FG-(40, 50, 60, 80, 100, 120)-S

KFM-FG-(40, 50, 60, 80, 100, 120)-R

**FLAT GLASS DELI CASE
DESIGNED FOR FRESH MEAT**

CASE HOLDS 33°F TO 40°F • LOW VELOCITY FORCED AIR REFRIGERATION MAINTAINS HIGH HUMIDITY
TEMPERED TILT OUT FLAT FRONT GLASS • TEMPERED SIDE GLASS & REAR SLIDING DOORS
CASES CAN BE MULTIPLEXED



AUTODESK®
REVIT®



FLAT GLASS DELI CASE DESIGNED FOR FRESH MEAT

SELF CONTAINED	Model	O.A. Length (inches)	Volume FT ³	Electrical 115 Volts					NEMA 115 V Plug	Weight lbs		Crate Size (inches)		
				Compressor		LIGHTS Fans HTRS	EVAP PAN	Total Amps		No Crate	With Crate	L"	W"	H"
				H.P.	F.L.A.									
	KFM-FG-40-S	40.4	15.35	3/8	8.4	0.95	3.3	12.68	5-15P	350	512	48	44	42
	KFM-FG-50-S	52.2	20.22	1/2	9.6	0.96	3.3	13.89	515P	399	582	59	44	42
	KFM-FG-60-S	60	23.47	1/2	9.6	1.08	3.3	14.01	5-15P	451	650	67	44	42
	KFM-FG-80-S	77.5	30.70	5/8	8.9	1.68	3.3	13.91	5-15P	561	825	85	44	42
	KFM-FG-100-S	101.2	40.45	3/4	16	1.81	3.3	21.14	N/A	695	974	109	44	42
	KFM-FG-120-S	117	46.95	3/4	16	2.06	3.3	21.39	N/A	830	1204	124	44	42

REMOTE	Model	O.A. Length (inches)	115 Volts Total Amps	B.T.U	Weight lbs	
					No Crate	With Crate
					KFM-FG-40-R	40.4
KFM-FG-50-R	52.2	0.51	3015	344	526	
KFM-FG-60-R	60	0.63	3159	397	595	
KFM-FG-80-R	77.5	0.78	4345	529	791	
KFM-FG-100-R	101.2	0.91	5112	642	919	
KFM-FG-120-R	117	1.16	5472	765	1138	

STANDARD FEATURES

- CFC free injected foam insulation
 - Stainless steel interior
 - Stainless steel rear work bench
 - Silver colored PVC coated steel front panel
 - Black steel kick plate
 - Foamed polystyrene black end panels
 - Tempered tilt-forward front glass
 - Removable rear tempered glass sliding doors
 - LED lighting in canopy
 - Temperature and defrost regulated by a digital controller
 - Removable condensate evaporating pan for easy cleaning on self contained units
 - Slide out condensing unit on self-contained units
 - Digital thermometer
 - Levelling feet
- OPTIONAL FEATURES**
- Stainless steel exterior
 - Other colors available
 - Joining Kit
 - Partition
 - Condensate evaporating pan for remote cases
 - White epoxy bi-level wire racks; 2 or 3 level step sham
 - Scale stand with receptacle
 - Cutting board
 - Knife Support
 - Casters add 4-3/8" to height
 - Stainless steel legs are adjustable from 5-1/8" to 7-5/8"

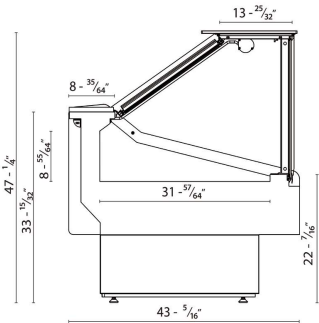

Standard Mounting



Levelling Feet

Optional Mounting



Adjustable Legs



Casters

NOTE

These cases are engineered to operate in locations not exceeding 75°F and 55% R.H. These cases are designed to operate using R404a refrigerant. Alternate refrigerants available by special order. O.A. length includes (2) ends at 1-1/2" each. Ventilation grills at front and back cannot be blocked. B.T.U.s are calculated at 14°F (evaporator) and 90°F (ambient). Remote cases are provided with an expansion valve and a liquid solenoid for pump down cycle. On remote cases, if no floor drain is provided, a condensate evaporating pan must be ordered and 3.3 amps added to the amp load. Remote cases must be hard wired – no plugs.

WARRANTY

One year parts and labor with an additional four years on the compressor (part only)



Hydra - Kool is a registered trademark of MVP Group Corp. SPECIFICATIONS SUBJECT TO CHANGE WITHOUT NOTICE

USA Tel: 786.600.4687 / Toll Free: 844.218.8477
Fax: 786.661.4100

Canada Tel: 514.737.9701 / Toll Free: 888.275.4538
Fax: 514.342.3854 / toll free: 877.453.8832

sales@mvpgroupcorp.com / mvpgroupcorp.com