

PROJECT: _____

LOCATION: _____

ITEM#: _____

QUANTITY: _____

C-1RB-HC

C-2RB-HC

C-3RB-HC

BOTTOM MOUNT REACH-IN REFRIGERATORS

- Beautiful ergonomic construction & rounded corners
- Digital temperature controller & read-out
- All stainless steel exterior and interior
- Forced air refrigeration system
- Recessed door handles
- LED Interior Lighting
- Door locks
- 90 degree hold open door feature for loading products
- Migali® Protection Plan: 1 Year Parts & Labor Warranty, 5 Years Compressor Warranty
- Bottom mount compressor for enhanced efficiency
- Pre-installed casters and shelving
- Auto-defrost
- Air plenum across back wall for even temperature distribution throughout cabinet interior
- All Natural R290 Hydrocarbon Refrigerant
- US Department of Energy Certified

MODEL	DOORS	CAPACITY CU/FT	SHELVES	H/P	AMPS	VOLTAGE	ENERGY CONSUMPTION KWH/24 HR	PLUG TYPE	TEMP RANGE	EXTERIOR DIMENSIONS W X D X H*	INSIDE DIMENSIONS W X D X H**	PACKAGED DIMENSIONS W X D X H**	WEIGHT	PACKAGED WEIGHT
C-1RB-HC	1	23	3	1/6	3.5	115/60/1	2.08	Nema 5-15P	+33° F (~) +41° F	27" x 31.5" x 83.2"	22.25" x 25.25" x 60"	29" x 33.5" x 86.2"	264 lbs.	284 lbs.
C-2RB-HC	2	49	6	1/3	5.6	115/60/1	3.24	Nema 5-15P	+33° F (~) +41° F	54.4" x 31.5" x 83.2"	49.63" x 25.25" x 60"	56.4" x 33.5" x 86.2"	405 lbs.	420 lbs.
C-3RB-HC	3	72	9	1/2	7.6	115/60/1	4.28	Nema 5-15P	+33° F (~) +41° F	81.9" x 31.5" x 83.2"	77.12" x 25.25" x 60"	83.9" x 33.5" x 86.2"	557 lbs.	579 lbs.

* Total height includes casters

NOTE: MIGALI® RESERVES THE RIGHT TO CHANGE SPECIFICATIONS WITHOUT NOTICE

DIMENSIONAL DRAWINGS

C-1RB-HC

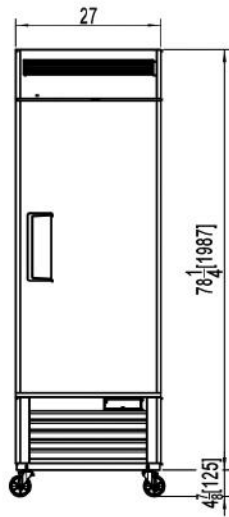

C-2RB-HC

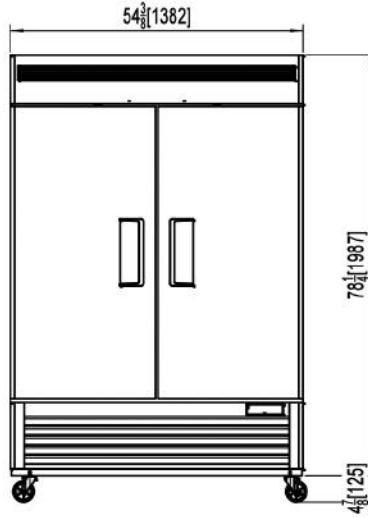

C-3RB-HC

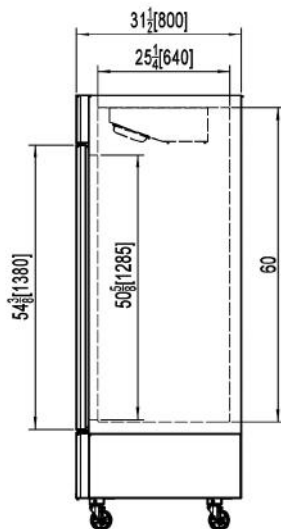
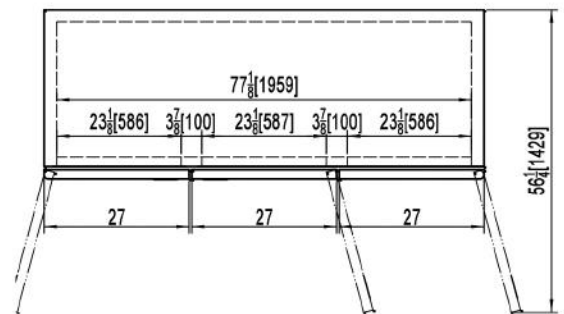
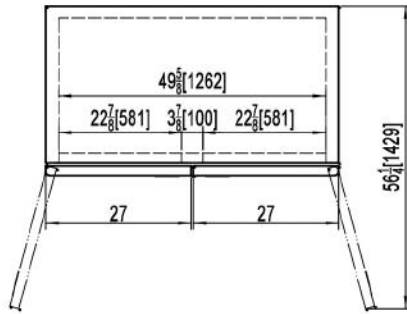
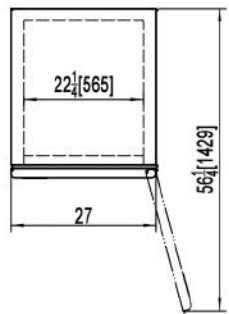
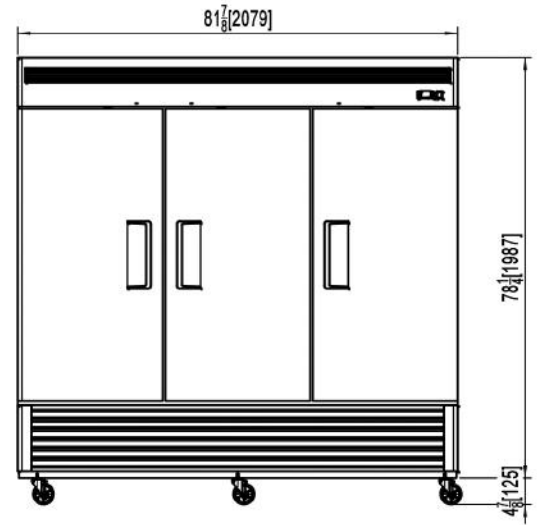

SIDE VIEW (1,2,3) DOOR MODELS



MIGALI® REMAINS AN AMERICAN FAMILY COMPANY SINCE 1955