



SRM20/SRMF20 PLANETARY MIXER OPERATOR'S MANUAL



Persons under age 18 are not permitted to operate or have accessibility to operate this equipment per U.S. Dept. Of Labor Employment Standards Administration Fact Sheet No. ESA913.

Welcome to Univex

Thank you for purchasing this Univex Product.

Your new SRM20 / SRMF20 mixer has been designed with advanced performance and safety features that make it an excellent addition to your food preparation equipment. Like all Univex mixers, slicers, meat grinders and accessories, this mixer is engineered to provide years of reliable service.

If you have any questions concerning the operation of this unit, or if we can be of further assistance, please call our Customer Service Department for the location of your nearest service representative.

Univex Customer Service:

USA & Canada 800-258-6358

International 603-893-6191

Or visit us on-line at www.univexcorp.com under service agents.

Safety is our top priority

READ AND MAKE SURE THAT YOU UNDERSTAND THE INSTRUCTIONS AND SAFETY WARNINGS IN THIS BOOKLET BEFORE ATTEMPTING TO OPERATE THE MIXER OR ATTACHMENTS.

NEVER PUT FINGERS OR HANDS IN THE BOWL WHILE THE MIXER IS OPERATING OR SERIOUS INJURY COULD RESULT.

NEVER ATTEMPT TO CLEAR A JAMMED ATTACHMENT OR STALLED MIXER WITHOUT SHUTTING THE POWER OFF AND DISCONNECTING THE ELECTRICAL POWER SUPPLY CORD.

ALWAYS REPLACE THE POWER TAKE-OFF (PTO) CAP WHEN ATTACHMENTS ARE NOT IN USE.

DO NOT OPERATE THIS MIXER WITHOUT THE BOWL IN PLACE

DO NOT OPERATE THIS MIXER WITHOUT THE SWING RING SAFETY GUARDS IN PLACE.

TABLE OF CONTENTS

DESCRIPTION	PAGE
TABLE OF CONTENTS, LIST OF ILLUSTRATIONS	2
CHOOSING THE RIGHT LOCATION FOR YOUR MIXER	3
USER FRIENDLY SWING RING SAFETY GUARD.....	3-4
OPERATING THE SRM20/SRMF20 MIXER	4-6
USING THE POWER TAKE-OFF (PTO)	7
TABLE OF MIXING CAPACITIES AND RECOMMENDED AGITATORS	8
BEATERS, AGITATORS, BOWLS, AND ACCESSORIES	9
CLEANING YOUR MIXER	11
OPERATOR'S PREVENTIVE MAINTENANCE.....	11-11.1
TROUBLE SHOOTING GUIDE	12
WARRANTY	BACKCOVER

LIST OF ILLUSTRATIONS

ILLUSTRATION

FIGURE 1 OVERALL VIEW OF MIXER	10
FIGURE 2A WIRING DIAGRAM 115/208-230V, 60HZ, 1PH 220-240V, 50HZ, 1PH 100V, 50HZ, 1PH	13
FIGURE 2B WIRING DIAGRAM 115V, 60HZ, 1PH (FOR CANADA ONLY) 220-240V, 50HZ, 1PH (FOR EUROPE ONLY).	14
FIGURE 2C WIRING DIAGRAM 380-400V, 50HZ, (FOR EUROPE ONLY)	15

CHOOSING THE RIGHT LOCATION FOR YOUR NEW MIXER

When selecting the best location for the mixer, it is helpful to consider the following:

- Where is the best location for the operator, both for saving steps and easy viewing?
- Is this a good location for product flow as in:
 - Easy to get ingredients to the mixer?
 - Destination of the mix after mixing?
 - Is there existing electrical service at this location?
 - Does this location provide easy access for cleaning and service?
 - Check to be sure that your mixer with attachments does not extend out into heavy traffic areas.
 - If stands and / or portable equipment are to be used along side of your mixer, can they be moved easily to and from your mixer?

IMPORTANT ELECTRICAL SERVICE INFORMATION

Electrical wiring instructions are found in the wiring diagram (Figures 2A thru 2C) on pages 13 through 15. Before making electrical connections, CHECK the specifications on the nameplate to make sure that they agree with the available electrical service.

USER FRIENDLY SWING RING SAFETY GUARD

Your SRM20 / SRMF20 mixer features a two part safety guard. The Swing Ring Safety Guard is easily removed and installed, as well as dishwasher safe. It conveniently swings out of the way without having to be removed to place or sample ingredients in the bowl. Only one side of the guard needs to be open when adding ingredients. This two-piece design handles and fits conveniently in your sink or dishwasher. It also provides a clear view of the product throughout the mixing cycle.

This mixer will not operate unless the Swing Ring Safety Guard is properly engaged.

The guards activate safety switches that enable the mixer to operate only when the guards are closed. These switches protect against accidental operation of the mixer when the guards are open or removed from the mixer. The mixer will automatically stop if the guard is opened. An additional switch in the bowl lift automatically stops the mixer if the bowl is lowered from the “up” (mixing) position.

To install the Swing Ring Safety Guard, insert the pointed end of the rod at the rear of the guard into the lower mounting bracket on the mixer housing. Then insert the top end of the rod into the upper bracket by aligning the groove in the rod with the slot in the bracket. Press the rod in and allow it to drop down into position. Swing the two halves of the guard forward. Magnets located on the transmission will hold the guards in position. When the guard is properly closed, the switches will be activated and the mixer can be operated.

To remove the guard, simply reverse the installation procedure. Grip the two halves of the guard and pull it open. Use an upward motion to release each half of the guard from the bracket on the machine body.

To open the guard for access to the bowl, **first turn the mixer off** by pushing the red “Stop” push-button (Figure 1 [14]). Pull open the two halves of the guard and swing one or both guards outward. It is not necessary to remove them. Close the guards and press the green “Start” push-button (Figure 1[13]) to resume mixing operations.

OPERATING THE SRM20 / SRMF20 MIXER

Your Univex mixer is designed to meet the cook’s and baker’s demand for an efficient, dependable appliance. It should give unfailing performance over a period of years when operated and maintained according to the instructions contained herein.

The mixer drives various agitator attachments through a beater head shaft to beat, mix, or whip liquid, viscous, or dry ingredients. The shaft is driven by a sturdy motor whose power is transmitted by a rugged, cogged belt and a continuously variable transmission (CVT) through a gear train and a planetary gear set. The speed of the beater shaft can be varied from approximately 90 to 365 revolutions per minute (RPM). (See page 9 for part numbers of various agitators, attachments and accessories.)

The SRM20 mixer is optionally equipped with a power take-off (PTO) that operates other attachments such as slicers, graters and grinders. The PTO speed can be varied from 60 to 240 rpm. **Be sure to read and follow all safety instructions provided by the manufacturers of attachments that you operate on the PTO.** The PTO hub should be covered with the PTO cap provided with your mixer when not in use to prevent accidental insertion of fingers into the PTO housing during operation.

Warning: Never put hands, spoons, utensils or other objects into the bowl while the mixer is operating!

Note: Noise emissions for this mixer are below 70db (A).

SECURING THE BOWL AND INSTALLING THE MIXER AGITATOR

Place the bowl on the bowl support (Figure 1 [17]). The pin at the rear of the bowl must align with the corresponding slot on the bowl support. Align the holes in the bowl mounting brackets with the pins on the bowl support and lower the bowl into position.

With the bowl in the “down” position, install the desired agitator by sliding it upward on the beater head shaft (Figure 1[1]). Rotate the agitator counter-clockwise until it is engaged.

Note: Serious injury may result if the bowl is not positioned properly on the bowl support using the bowl support pins.

With the bowl secured, add ingredients. Liquids should be added first. The bowl is now ready to be raised to the “up”(mixing) Position by turning the bowl lift handle (Figure 1 [15]) clockwise.

Note: Exceeding the mixer capacity (page 8) can cause damage to the mixer and will void the factory warranty.

When using the wire whip agitator, raise the bowl to the “up” position first and then add ingredients to avoid wire whip damage.

Close and secure the Swing Ring Safety Guard before proceeding.

USING THE BOWL LIFT

The mixer will not operate unless the bowl is in the “up” position. Raise the bowl by turning the bowl lift handle (Figure 1 [15]) clockwise. To lower the bowl, turn the bowl lift handle counter-clockwise. It is necessary to lower the bowl to change the agitator. This also makes the bowl accessible for filling.

START/STOP CONTROLS

This mixer will start only when the Swing Ring Safety Guard is closed and the bowl is in the raised position. (If the optional timer is installed, the timer must be set). To start the mixer, push the Green “Start” push-button (Figure 1 [13]). For safety and operator ease, this mixer is equipped with an oversized, red mushroom style stop button (Figure 1 [14]).

NOTE: Although the motor shuts off instantly when the Swing Ring Safety Guard is opened, or the bowl is lowered, or the stop button is pushed, the agitator may **NOT** come to a complete stop for several revolutions. **DO NOT PUT HANDS OR UTENSILS INTO THE BOWL OR NEAR THE BEATER HEAD SHAFT UNTIL IT HAS FULLY STOPPED.**

Both the Start and Stop push-buttons are momentary contact type buttons. They provide low voltage protection and prevent accidental start-up in the event of power interruption.

SETTING THE TIMER (if provided)

When the mixer is equipped with a timer, the mixer will not operate unless the timer has been set or placed in the “HOLD” position. To start the mixer, first turn the timer (Figure 1 [12]) to the desired mixing time. Then push the green “Start” push-button (Figure 1 [13]). The mixer will automatically stop when the timer has reached “0”. To stop the mixer before the timer has reached “0”, push the red “Stop” push-button (Figure 1 [14]). The timer may be set for up to 15 minutes or may be set to the “HOLD” position for continuous operation. When setting a time of less than 5 minutes, turn the timer beyond 5 minutes and then return it to the desired time.

NOTE: The mixer will start only when the Swing Ring Safety Guard is closed and the bowl is in the raised position. Do not operate the mixer without the bowl in place.

VARI-SPEED CONTROL

A major advantage of Univex mixers is their Continuously Variable Transmission (CVT). Unlike other mixers, CVT lets you change speeds while the mixer is running. To change speeds move the speed control lever (Figure 1 [9]) to the desired speed. The speed indicator (Figure 1 [10]) shows four speeds.

Numerous intermediate speeds give the cook or baker tremendous flexibility.

Use speed “1” (slow) for heavy mixtures like pizza, bread or roll dough. Speed “1” should also be used with the meat and food chopper attachment. For most mixing tasks, start on speed “1” and progress to higher speeds as needed. Use high speeds for whipping cream and beating eggs, and thin batter. To avoid damaging your mixer, follow the speed, volume limits and attachments recommendations shown in the table of mixing capacities on pages 8.

If you notice any slippage during mixing, the mixer may be overloaded. Reduce the load, or reduce the speed until the mixing action is smooth. Refer to the Trouble-Shooting Guide on page 12.

If the mixer jams and the motor stalls, immediately press the “Stop” push-button. Take necessary steps to reduce the load. Never put hands in the bowl to clear a jam.

NOTE: Always return to speed “1” before shutting the mixer off. Do not move the speed control lever when the mixer is not running, because this will cause the belt to become loose and the mixer will not operate properly.

If the mixer has been shut off by the timer, or the stop button in speed 2, 3 or 4, follow these steps to avoid belt slippage or jerky start: Empty the bowl. Set the timer to “HOLD”. Press the start button and as the mixer begins to operate, move the speed control lever back to speed “1”. Press the stop button and return the timer to “0”. Your mixer is now ready for use.

USING THE INGREDIENTS CHUTE

The ingredients chute provided with your mixer enables you to add ingredients to the bowl while the mixer is running and without opening the Swing Ring Safety Guard. The chute may be installed on the front or side of either half of the guard. Once the chute is properly installed, it can remain in place permanently, if desired.

INGREDIENTS CHUTE INSTALLATION

Slide the bottom of the chute between horizontal safety guard rings and engage the chute onto the safety guard.



USING A SMALLER BOWL

For maximum flexibility, a 12 quart bowl is available for use on the SRM20/SRMF20 mixer. Specially sized agitators must be used. See page 9 for part numbers for these parts.

SPLASH / EXTENSION RING

A splash/extension ring (Page 9 [H]) mounted to the bowl helps confine ingredients during the mixing of certain recipes. Never use the ring to overload the bowl. Consult the Table of Mixing capacities on pages 8 for appropriate loads.

NOTE: Overloading the mixer beyond the factory specifications can damage the mixer and will void the warranty.

USING THE POWER TAKE-OFF (PTO)

The Power Take-Off (PTO) hub (Figure 1 [5]) accommodates #12 tapered attachments such as a vegetable slicer and shredder, or a meat and food chopper. The mixers speed control lever also controls the PTO drive speed.

Before installing attachments, turn the mixer off. Remove the PTO cap and loosen the thumb screw (Figure 1 [6]) on the PTO hub. Insert the attachment with a slight twist until it is firmly in place. Tighten the thumb screw. **Be sure to read and follow all safety instructions provided for the attachments that you operate on the PTO.**

SAFETY NOTES:

When grinding meat, chopper attachments must never run faster than speed 1. For vegetables, attachments may run at a higher speed.

Always turn the mixer off to install or remove the attachment.

Always return to speed 1 before shutting the mixer off.

Cover the PTO hub with the PTO cap when the PTO is not in use.

SRM20/SRMF20 Table of Mixing capacity and Recommended Agitators

MODEL		SRM20 / SRMF20	
Bowl capacity Attachment Hub Size Motor		22 qt. #12 1/2Hp	20.8 L
Kitchen Capacities (single batches)	Agitator		
Mashed potatoes	Batter beater, 4-Wing beater	15 lb.	6.8 kg.
Whipping cream	Wire whip, 4-Wing beater	4 qt.	3.8 L.
Mayonnaise	Batter beater, Wire whip, 4-Wing beater	10 qt. (oil)	9.5 L. (oil)
Egg whites	Wire whip	1 qt.	0.9 L.
Meringue	Wire whip	1-1/2 pt.(water)	0.7 L. (water)
Waffle or pancake batter	Batter beater	8 qt.	7.6 L.
Bakery Capacities (single batches)	Agitator		
Pie dough	Pastry knife	18 lb.	8.2 kg.
Cake	Batter beater, 4-Wing beater	21 lb.	9.6 kg.
Sponge cake batter	Wire whip, 4-Wing beater	12 lb.	5.5 kg.
Angle food batter (8-10 oz. cake)	Wire whip, 4-Wing beater	15 cakes	15 cakes
Marshmallow icing	4-Wing beater	2 lb.	0.9 kg.
Fondant icing	Batter beater	12 lb.	5.5kg.
Shortening & sugar creamed	Batter beater	16 lb.	7.3 kg.
Egg & sugar for sponge cake	Batter beater, 4-Wing beater	8 lb.	3.6 kg.
Use only speed 1 for:			
Pizza dough			
Thin, 40% AR	Dough hook	9 lb.	4.1 kg.
Medium, 50% AR	Dough hook	10 lb.	4.6 kg.
Thick, 60% AR	Dough hook	20 lb.	9.1 kg.
Use only speed 1 or 2 for:			
Bread / roll dough			
Heavy, 55% AR	Dough hook	15 lb.	6.8 kg.
Light to medium 60% AR	Dough hook	25 lb.	11.4 kg.
Raised doughnut dough 65% AR	Dough hook	9 lb.	4.1 kg.

NOTES: Recommended speeds are for the capacities listed.

Dough capacity, for bread, rolls, pizza, bagels or doughnut, is based on a 12% flour moisture and 70°F (21°C) water temperature. Reduce capacity by 10% if cold water is used.

If higher gluten flour is used, reduce total capacity by 10%.

AR% (Absorption Ratio) = the weight of the water divided by the weight of the flour.

The lower the AR% the stiffer and more difficult the dough is to mix.









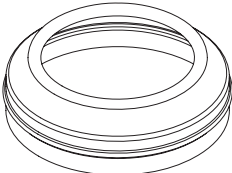

An AR% below 40% will reduce the total capacity.

1 Gallon of water = 8.3 lb. (1 liter of water = 2.2lb.)

Beaters, Agitators, Bowls, and Accessories

Available for the SRM20/SRMF20 Mixer

Part numbers (size in quarts)

<p>A. Batter Beater 1023083 (20)</p> <p>Optional 1020096 (12 for 20)</p>		<p>G. Bowl 1020091 (20)</p> <p>Optional 1020092 (12 for 20)</p>	
<p>B. Wire Whip 1020095 (20)</p> <p>Optional 1020086 (12 for 20)</p>		<p>H. Splash/Extension Ring Optional 1021299 (20)</p>	
<p>C. Dough Hook Optional 1023089 (20) 1020090 (12 for 20)</p>		<p>I. Vegetable Slicer/Grater Optional VS9 Slicer 1000950 VS9H Grater 1001050</p>	
<p>D. Pastry Knife Optional 1023087 (20) 1020088 (12 for 20)</p>		<p>J. Meat & Food Chopper Optional ALMFC12 1000550</p>	
<p>E. 4-Wing Beater Optional 1020197 (20) 1220197 (12 for 20)</p>		<p>K. Ingredient Chute 1000541</p>	
<p>F. sweet Dough Beater Optional 1020195 (20) 1220238 (12 for 20)</p>			

OVERALL VIEW OF FOOD MIXER

FIGURE 1

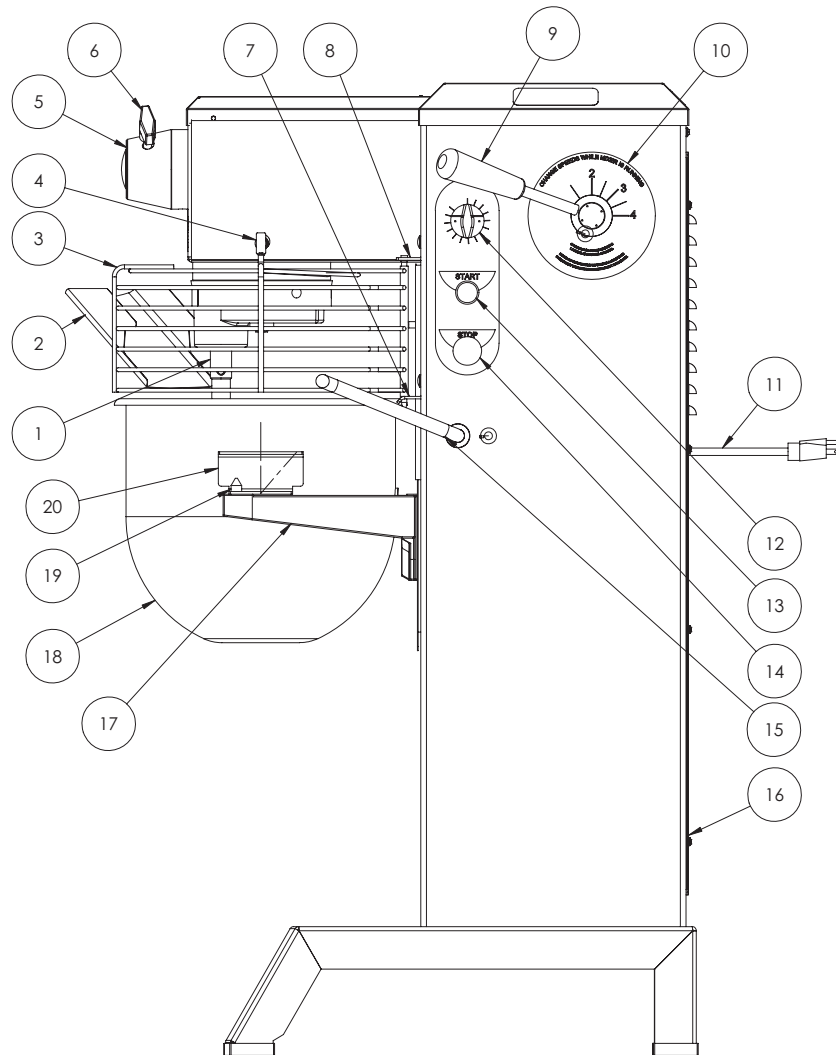

- | | |
|-----------------------------|-------------------------------|
| 1. BEATER HEAD SHAFT | 11. POWER CORD |
| 2. INGREDIENT CHUTE 1000541 | 12. TIMER (OPTIONAL) |
| 3. SWING RING SAFETY GUARD | 13. START PUSH-BUTTON (GREEN) |
| 4. MAGNET | 14. STOP PUSH-BUTTON (RED) |
| 5. PTO HUB #12 | 15. BOWL LIFT HANDLE |
| 6. THUMB SCREW | 16. REAR ACCESS PANEL |
| 7. LOWER MOUNTING BRACKET | 17. BOWL SUPPORT |
| 8. UPPER MOUNTING BRACKET | 18. BOWL |
| 9. SPEED CONTROL LEVER | 19. BOWL SUPPORT PIN |
| 10. SPEED INDICATOR LABEL | 20. BOWL MOUNTING BRACKET |

CLEANING YOUR MIXER

Consistent use of the following procedures will ensure that your mixer is in optimum operating condition.

- **Warning: disconnect the electrical power supply cord before cleaning.**
- Wash the body of the mixer, the bowl support, and the beater shaft with warm water and mild soap.
- Avoid excess water in the area of the safety switches that protrude from the housing where the Swing Ring Safety Guard is mounted.
- Do not rinse the mixer with a hose.
- Do not use abrasive pads to wash the mixer.
- Dry the mixer thoroughly with a soft cloth.
- Wash the bowl and beater immediately after use. If an egg mixture or flour batter have been used, rinse the bowl and beater with cold water before washing with hot water. Wash the Swing Ring Safety Guard in the same manner, or in a dishwasher.
- Dry bowls and beaters and the Swing Ring Safety Guard thoroughly.

OPERATOR'S PREVENTIVE MAINTENANCE

For best long-term performance, operators should follow these simple practices:

- Lightly lubricate the beater shaft (Figure 1 [1]) after washing. Food grade lubricant should be used.
- Do not cover the mixer with a plastic bag, as this traps humidity inside the mixer.
- If the electrical power supply cord becomes damaged, it must be replaced by an approved cord or assembly available from Univex directly or from a Univex service agent.
- Do not overload the mixer. **Overloading is the #1 cause of mixer failure.** Follow the Table of Mixing Capacities on pages 8. It may be helpful to post a copy of this table adjacent to the mixer.
- Keep the mixer properly lubricated. **Lack of lubrication is the #2 cause of mixer failure.** Key mixer components require lubrication after each 500 hour of operation.
- Only change speeds with the mixer running. **Changing speeds with the mixer off will cause the belts to loosen, and the mixer will not turn** (see the Trouble-Shooting Guide on page 12). Return to speed "1" before shutting the mixer off. Use the procedure described on page 6 to return the mixer to speed "1" if the mixer is shut off in a higher speed.

LUBRICATION

The lubrication instructions are in Figure 2. The motor has pre-lubricated bearings with a service interval of ten years. The transmission and beater head gearing are packed with Nevastane 5P7 grease.

WARNING: NEVER WORK ON THE TRANSMISSION WITH THE MIXER RUNNING. IT IS RECOMMENDED THAT THE ELECTRICAL SERVICE POWER CORD BE DISCONNECTED TO PREVENT ACCIDENTAL START UP.

LUBRICATION INSTRUCTIONS

FIGURE 2

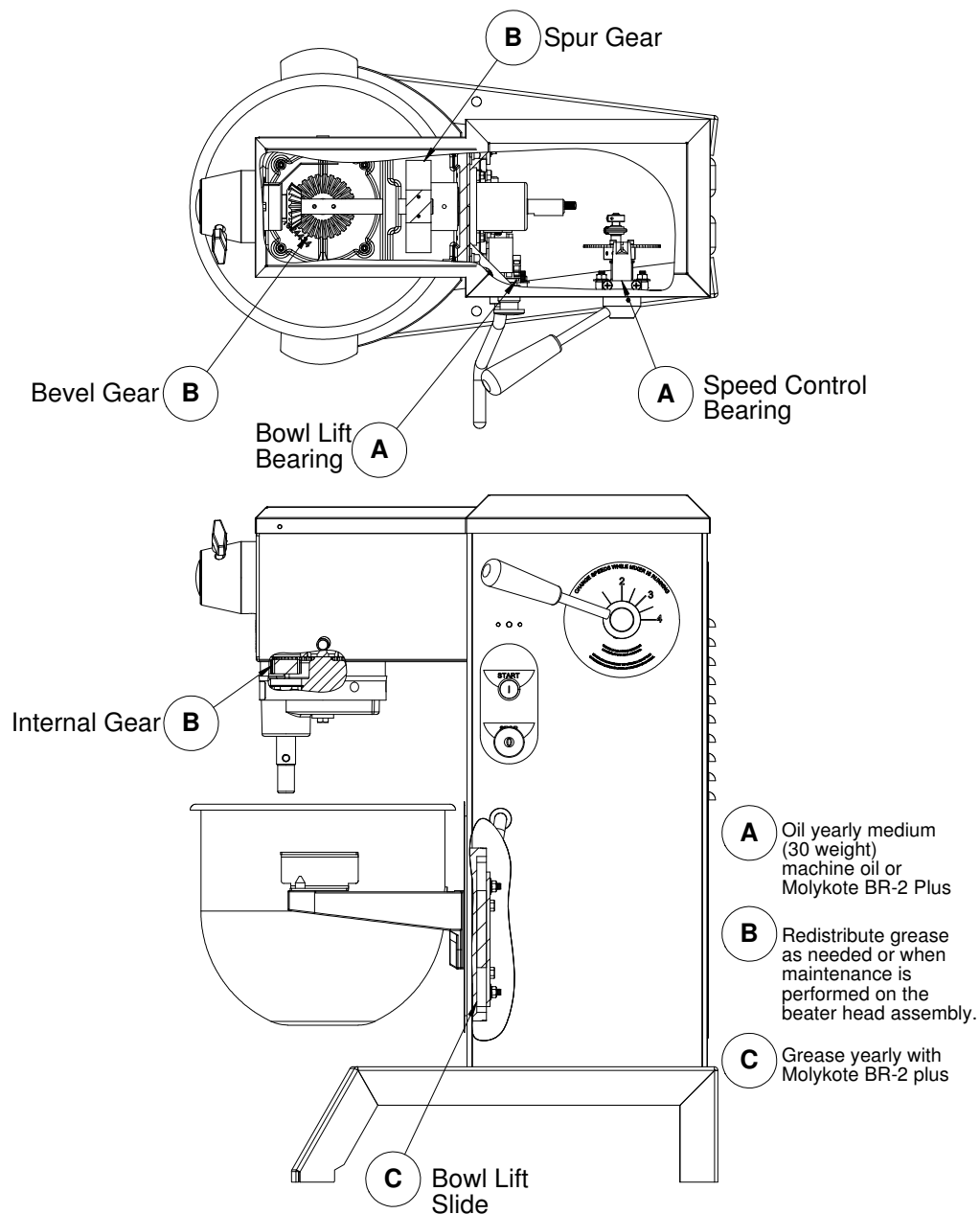

SRM20/SRMF20 TROUBLE-SHOOTING GUIDE

TROUBLE	POSSIBLE CAUSE	REMEDY
1. Mixer will not operate	1.1 Electrical service down. 1.2 Burned switch contacts. 1.3 Timer not turned on. 1.4 Motor capacitor defective 1.5 Burned out motor. 1.6 Safety Ring not mounted and closed. 1.7 Bowl not raised.	1.1 Check electrical service. Replace fuse or reset circuit breaker as necessary. 1.2 Replace or clean contacts. * 1.3 Turn timer on. 1.4 Replace capacitor. * 1.5 Remove, test, repair or replace. * 1.6 Install Safety Ring. 1.7 Raise bowl completely.
2. Mixer runs but agitator will not turn.	2.1 Shifting speed with the mixer not running. 2.2 Broken or slipping belt. 2.3 Key or pin sheared on input shaft, input gear, bevel pinion, vertical shaft or beater shaft	2.1 With mixer running, slowly move speed control lever forward then backward to re-engage belt. 2.2 Tighten or replace. * 2.3 Notify a service agent.
3. Agitator stalls during mixing.	3.1 Loose belt. 3.2 Mixer bowl is over-loaded. 3.3 Speed set too high for the mix. 3.4 Contamination of belt with grease.	3.1 Readjust pulley center distance to tighten belt. * 3.2 Adjust contents of bowl per Mixing Capacities Table. 3.3 Shift speed lower till beater head rotates smoothly. 3.4 Clean pulleys and replace belt. *
4. Speeds will not change properly.	4.1 Loose belt. 4.2 Vari-speed pulley inoperable.	4.1 Readjust pulley center distance to tighten belt. * 4.2 Remove, clean and lubricate or replace.*
5. Attachments contact bottom of bowl.	5.1 Dented bowl. 5.2 Insufficient clearance between bottom of bowl and beater. 5.3 Misalignment of transmission in relation to bowl support.	5.1 Remove dent or replace bowl. 5.2 Readjust bowl lift. * 5.3 Realign transmission. *
6. Excessive noise.	6.1 Gears need to be repacked with grease. 6.2 Badly worn or frayed drive belts. 6.3 Attachments hitting bowl. 6.4 Overloaded mixing bowl.	6.1 Notify a service agent. 6.2 Replace belt. * 6.3 Inspect for cause in items 5 above. 6.4 Adjust contents of bowl per Mixing Capacities Table.
7. Difficulty in raising or lowering the bowl	7.1 Lack of adequate lubricant on bowl lift slide assembly and housing	7.1 Lubricate bowl lift bearing with grease.*

* Remedies designated with an * require the service of an authorized service agent.

WIRING DIAGRAM

(115/208-230V, 60HZ, 1PH) (220-240V, 50HZ, 1PH) (100V, 50HZ, 1PH)

FIGURE 2A

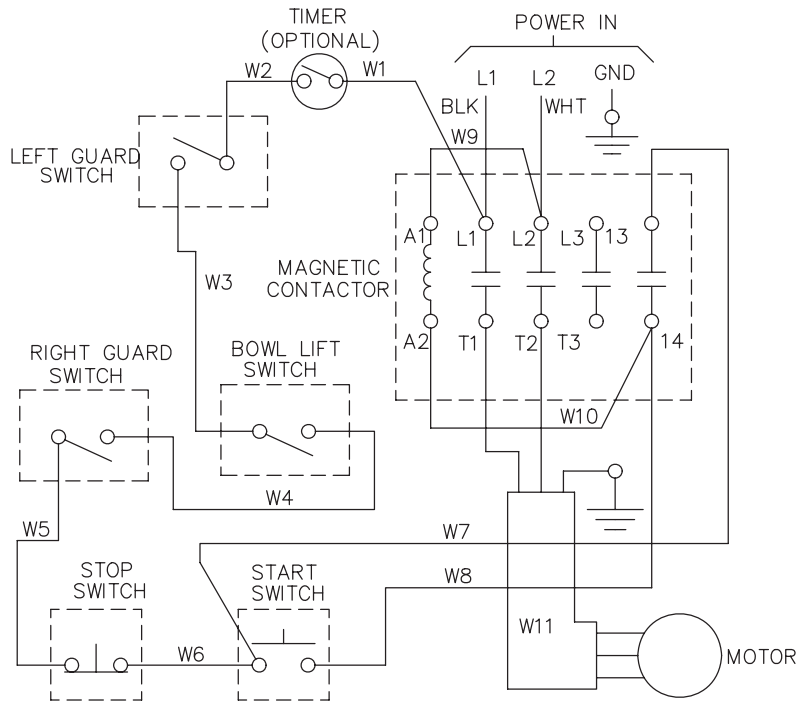

WIRE TABLE							
PART NUMBER	WIRE NO	GA	SEE NOTE	LENGTH IN INCHES	END A SEE NOTE	END B SEE NOTE	COLOR
8800221	W1	16	3				
	W2	16	3				
	W1 W/O TIMER	16	3	21	1	2	WHITE
	W3	16	3	4	2	2	BLACK
	W4	16	3	7	2	2	WHITE
	W5	16	3	4	1	2	RED
	W6	16	3	2 1/2	1	1	RED
	W7	16	3	26 1/2	1	1	BLACK
	W8	16	3	30	1	1	RED
	W9	16	3	2 1/2	1	1	RED
8800203	W11						

- NOTES: 1. ATTACH DOUBLE CRIMP FERRULE.
 2. ATTACH DOUBLE CRIMP 1/4" FEMALE QUICK DISCONNECT FULLY INSULATED.
 3. MATERIAL: 1015 TEW CSA AND UL APPROVED.

IMPORTANT: Before making any electrical connections, check the specifications on the data plate, (located on the rear access panel Figure 1 [16]), to make sure that they agree with those of your electrical service.

WARNING: Whenever maintenance is being performed, or whenever the top cover or rear access panel have been removed, **DISCONNECT THE ELECTRICAL POWER SUPPLY CORD** and place a tag on it indicating that the mixer is being worked on.

WIRING DIAGRAM
115V, 60HZ, 1PH (FOR CANADA ONLY)
220-240V, 50HZ, 1PH (FOR EUROPE ONLY)

FIGURE 2B

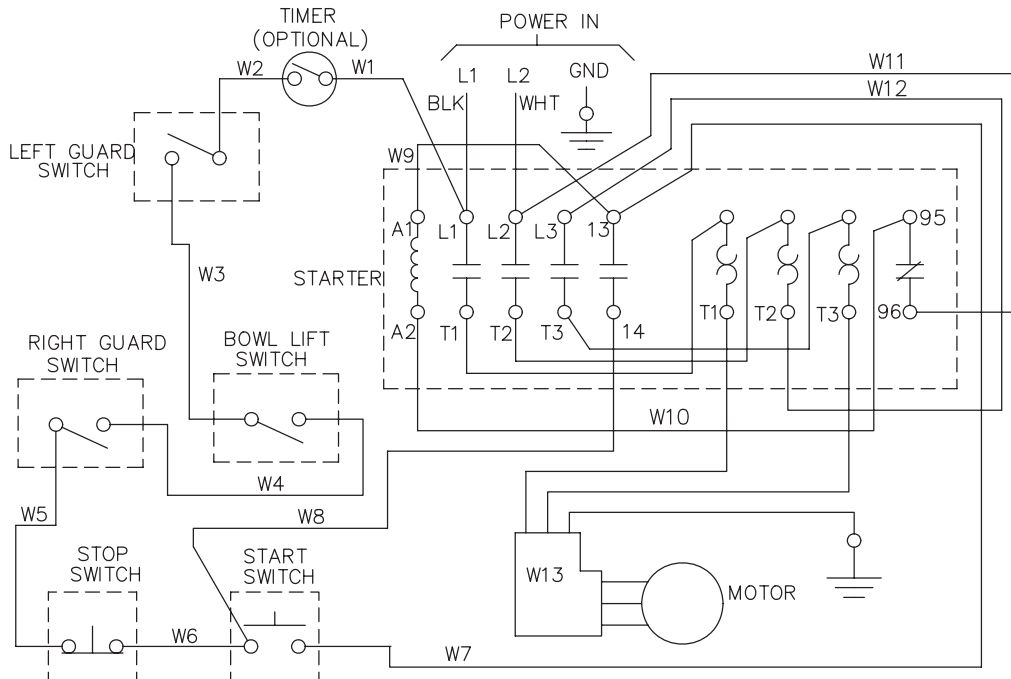

WIRE TABLE							
PART NUMBER	WIRE NO	GA	SEE NOTE	LENGTH IN INCHES	END A SEE NOTE	END B SEE NOTE	COLOR
8800221	W1	16	3				
	W2	16	3				
	W1 W/O TIMER	16	3	21	1	2	WHITE
	W3	16	3	4	2	2	BLACK
	W4	16	3	7	2	2	WHITE
	W5	16	3	4	1	2	RED
	W6	16	3	2 1/2	1	1	RED
	W7	16	3	26 1/2	1	1	BLACK
	W8	16	3	30	1	1	RED
	W9	16	3	2 1/2	1	1	RED
	W10	16	3	2 1/2	1	1	RED
	W11	16	3	10	1	1	RED
	W12	16	3	10	1	1	BLACK
8800203	W13						

- NOTES: 1. ATTACH DOUBLE CRIMP FERRULE.
2. ATTACH DOUBLE CRIMP 1/4" FEMALE QUICK DISCONNECT FULLY INSULATED.
3. MATERIAL: 1015 TEW CSA AND UL APPROVED.

IMPORTANT: Before making any electrical connections, check the specifications on the data plate, (located on the rear access panel Figure 1 [16]), to make sure that they agree with those of your electrical service.

WARNING: Whenever maintenance is being performed, or whenever the top cover or rear access panel have been removed, **DISCONNECT THE ELECTRICAL POWER SUPPLY CORD** and place a tag on it indicating that the mixer is being worked on.

WIRING DIAGRAM
380-400V, 50HZ, 3PH (FOR EUROPE ONLY)
FIGURE 2C

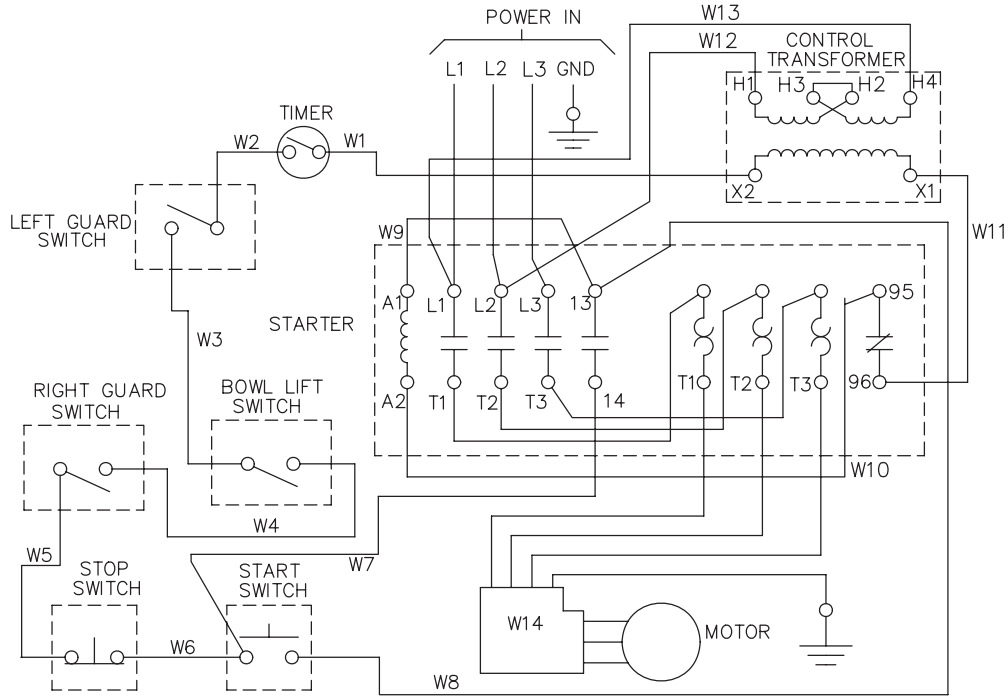

WIRE TABLE							
PART NUMBER	WIRE NO.	GA	SEE NOTE	LENGTH IN INCHES	END A SEE NOTE	END B SEE NOTE	COLOR
	W1	16	3				
	W2	16	3				
8800221	W1 W/O TIMER	16	3	21	1	2	WHITE
	W3	16	3	4	2	2	BLACK
	W4	16	3	7	1	2	WHITE
	W5	16	3	4	1	2	RED
	W6	16	3	2 1/2	1	1	RED
	W7	16	3	26 1/2	1	1	BLACK
	W8	16	3	30	1	1	RED
	W9	16	3	2 1/2	1	1	RED
	W10	16	3	2 1/2	1	1	RED
	W11						
	W12						
	W13						
8800226	W14	CORD					

- NOTES: 1. ATTACH DOUBLE CRIMP FERRULE.
2. ATTACH DOUBLE CRIMP 1/4" FEMALE QUICK DISCONNECT FULLY INSULATED
3. MATERIAL: 1015 TEW CSA AND UL APPROVED.

IMPORTANT: Before making any electrical connections, check the specifications on the data plate, (located on the rear access panel Figure 1 [16]), to make sure that they agree with those of your electrical service.

WARNING: Whenever maintenance is being performed, or whenever the top cover or rear access panel have been removed, **DISCONNECT THE ELECTRICAL POWER SUPPLY CORD** and place a tag on it indicating that the mixer is being worked on.

Warranty

The Univex SRM20 and SRMF20 mixer carries a two-Year, on-site, parts and labor warranty against any defects in materials or workmanship. The two-year period begins on the date of purchase by the end user and remains in full effect provided the unit is used properly in accordance with our instructions. Any Work to be performed under this warranty must be performed between the hours of 8:00 a.m. and 5:00 p.m. local time, Monday through Friday. Univex will not cover overtime charges of any kind. Please call the Univex Warranty Service Department at (800) 258-6358 to report any warranty claims before arranging repair or attempting to return the unit to Univex Corporation.

Damages incurred in transit or incurred because of installation error, accident, alteration or misuse are not covered. Transit damages should be reported to the carrier immediately.

Univex will not be liable for any consequential, compensatory, incidental or special damages.

