



**TRUE MANUFACTURING CO., INC.**  
**U.S.A FOODSERVICE DIVISION**

2001 East Terra Lane • O'Fallon, Missouri 63366-4434 • (636)240-2400  
 Fax (636)272-2408 • Toll Free (800)325-6152 • Intl Fax# (001)636-272-7546  
 Parts Dept. (800)424-TRUE • Parts Dept. Fax# (636)272-9471 • www.truemfg.com

Project Name: \_\_\_\_\_

Location: \_\_\_\_\_

Item #: \_\_\_\_\_ Qty: \_\_\_\_\_

Model #: \_\_\_\_\_

A/A #

SIS #

Model:

**TS-49-2-G-2-HC~FGD01**

**TS Series:**

*Reach-In Combination Half Swing Door Stainless Steel Refrigerator with Hydrocarbon Refrigerant-Framed Glass Door Version 01*



**TS-49-2-G-2-HC~FGD01**

- ▶ True's TS series is the choice for the exclusive stainless steel commercial application.
  - ▶ Designed using the highest quality materials and components to provide the user with colder product temperatures, lower utility costs, exceptional food safety and the best value in today's food service marketplace.
  - ▶ Factory engineered, self-contained, capillary tube system using environmentally friendly R290 hydro carbon refrigerant that has zero (0) ozone depletion potential (ODP), & three (3) global warming potential (GWP).
  - ▶ High capacity, factory balanced refrigeration system that maintains cabinet temperatures of 33°F to 38°F (.5°C to 3.3°C) for the best in food preservation.
  - ▶ Stainless steel interior and exterior front, sides and solid doors. The very finest stainless with higher tensile strength for fewer dents and scratches. Matching aluminum back.
  - ▶ Energy efficient, "Low-E", double pane thermal glass half doors.
  - ▶ LED interior lighting provides more even lighting throughout the cabinet. Safety shielded.
  - ▶ Adjustable, heavy duty PVC coated gray wire shelves.
  - ▶ Positive seal self-closing doors. Lifetime guaranteed door hinges and torsion type closure system.
- Bottom mounted units feature:**
- ▶ "No stoop" lower shelf.
  - ▶ Storage on top of cabinet.
  - ▶ Compressor performs in coolest, most grease free area of kitchen.
  - ▶ Easily accessible condenser coil for cleaning.

**ROUGH-IN DATA**

Specifications subject to change without notice.  
 Chart dimensions rounded up to the nearest 1/8" (millimeters rounded up to next whole number).

Model	Doors	Shelves	Cabinet Dimensions (inches) (mm)			HP	Voltage	Amps	NEMA Config.	Cord Length (total ft.) (total m)	Crated Weight (lbs.) (kg)
			L	D†	H*						
TS-49-2-G-2-HC~FGD01	4	6	54 1/8 1375	29 3/4 756	78 3/8 1991	1/2 N/A	115/60/1	5.4 N/A	5-15P	9 2.74	515 233

† Depth does not include 1 3/8" (35 mm) for door handle.  
 \* Height does not include 5" (127 mm) for castors or 6" (153 mm) for optional legs.

	<b>APPROVALS:</b>	<b>AVAILABLE AT:</b>
7/18	Printed in U.S.A.	

Model:  
**TS-49-2-G-2-HC~FGD01**

**TS Series:**

*Reach-In Combination Half Swing Door Stainless Steel Refrigerator  
with Hydrocarbon Refrigerant~Framed Glass Door Version 01*



**STANDARD FEATURES**

**DESIGN**

- True's combination door reach-in's are designed with enduring quality that protects your long term investment.
- True's commitment to using the highest quality materials and oversized refrigeration systems provides the user with colder product temperatures, lower utility costs, exceptional food safety and the best value in today's food service marketplace.

**REFRIGERATION SYSTEM**

- Factory engineered, self-contained, capillary tube system using environmentally friendly R290 hydro carbon refrigerant that has zero (0) ozone depletion potential (ODP), & three (3) global warming potential (GWP).
- High capacity, factory balanced refrigeration system that maintains cabinet temperatures of 33°F to 38°F (5°C to 3.3°C) for the best in food preservation.
- State of the art, electronically commutated evaporator and condenser fan motors. ECM motors operate at higher peak efficiencies and move a more consistent volume of air which produces less heat, reduces energy consumption and provides greater motor reliability.
- Bottom mounted condensing unit positioned for easy maintenance. Compressor runs in coolest and most grease free area of the kitchen. Allows for storage area on top of unit.

**CABINET CONSTRUCTION**

- Exterior - Stainless steel solid half doors, front and sides. Corrosion resistant GalFan coated steel back.
- Interior - Stainless steel liner and floor.
- Insulation - entire cabinet structure and solid doors are foamed-in-place using a high density, polyurethane insulation that has zero ozone depletion potential (ODP) and zero global warming potential (GWP).
- Welded, heavy duty steel frame rail, black powder coated for corrosion protection.
- Frame rail fitted with 4" (102 mm) diameter stem castors - locks provided on front set.

**DOORS**

- Solid half doors - stainless steel exterior and liners. Glass half doors - "Low-E", double pane thermal glass assembly(ies) with extruded aluminum frames. Door locks standard.
- Each solid door fitted with 12" (305 mm) long, lifetime guaranteed recessed handle. Each glass door fitted with 15" (381 mm) long extruded aluminum handle.
- Positive seal self-closing doors. Lifetime guaranteed door hinges and torsion type closure system.
- Magnetic door gaskets of one piece construction, removable without tools for ease of cleaning.

**SHELVING**

- Six (6) adjustable, heavy duty PVC coated gray wire shelves 24 9/16" L x 22 3/8" D (624 mm x 569 mm). Four (4) chrome plated shelf clips included per shelf.

- Aluminum shelf support pilasters. Shelves are adjustable on 1/2" (13 mm) increments.

**LIGHTING**

- LED interior lighting provides more even lighting throughout the cabinet. Safety shielded.

**MODEL FEATURES**

- Evaporator is epoxy coated to eliminate the potential of corrosion.
- Exterior solar, digital temperature display.
- NSF/ANSI Standard 7 compliant for open food product.

**ELECTRICAL**

- Unit completely pre-wired at factory and ready for final connection to a 115/60/1 phase, 15 amp dedicated outlet. Cord and plug set included.



115/60/1  
NEMA-5-15R

**OPTIONAL FEATURES/ACCESSORIES**

Upcharge and lead times may apply.

- 6" (153 mm) standard legs.
- 6" (153 mm) seismic/flanged legs.
- 2 1/2" (64mm) castors.
- Alternate door hinging (factory installed).
- Additional shelves.
- Half door bun tray racks. Each holds up to eleven 18"L x 26"D (458 mm x 661 mm) sheet pans (sold separately).

**PLAN VIEW**

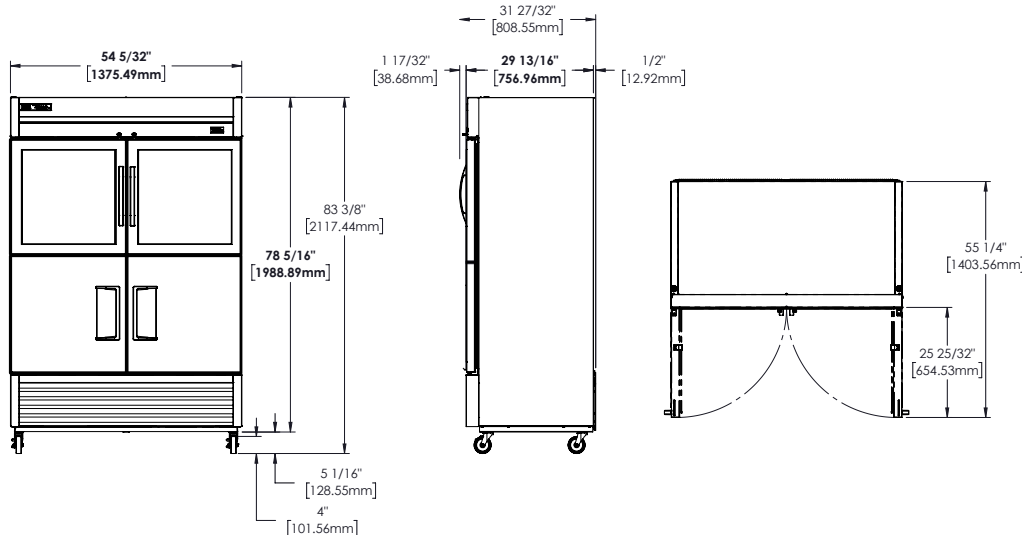

**WARRANTY**  
Three year warranty on all parts and labor and an additional 2 year warranty on compressor. (U.S.A. only)

METRIC DIMENSIONS ROUNDED UP TO THE NEAREST WHOLE MILLIMETER  
SPECIFICATIONS SUBJECT TO CHANGE WITHOUT NOTICE



Model	Elevation	Right	Plan	3D	Back
TS-49-2-G-2-HC~FGD01					

**TRUE MANUFACTURING CO., INC.**